

**Series 6, heat pump tumble dryer, 9 kg
WQG24200AU**



- **ActiveAir Technology** reuses existing heat efficiently during the entire drying process.
- **Auto Dry:** automatically dries to the exact degree of dryness you want.
- **Half load option:** optimises the drying settings (load and duration) for small loads.
- **Anti Vibration Design:** extremely stable and especially quiet thanks to special vibration protection.
- **Sensitive Drying System:** for gentle drying without wrinkles.

Built-in / Free-standing: Free-standing
 Removable top: No
 Door hinge: Right
 Length electrical supply cord: 145.0 cm
 Dimensions (HxWxD): 842 x 598 x 613 mm
 Net weight: 49.5 kg
 Fluorinated greenhouse gases: No
 Type of refrigerant: R290
 Hermetically sealed equipment: Yes
 The quantity expressed in CO2 equivalent: 0.000 t
 EAN code: 4242005238866
 Connection rating: 625 W
 Fuse protection: 10 A
 Voltage: 220-240 V
 Frequency: 50 Hz
 Capacity: 9.0 kg
 Energy efficiency rating: A++



- WMZ20600 Wool in basket - accessory
- WTZ1110 Condenser drainage kit
- WTZ11400 Stacking kit with pull-out shelf
- WTZ20410 Stacking kit
- WTZPW20D Platform with pull-out, dryer, cubic

Series 6, heat pump tumble dryer, 9 kg WQG24200AU

Capacity

- Capacity: 9 kg

Consumption rates

- 7 Star energy rating
- Energy consumption 170 kWh per year on Cottons, Cupboard Dry Plus, Drying level 1, used once per week. When tested in accordance with AS/NZS 2442.2. Actual energy use and running costs will depend on how you use the appliance.

Programs

- standard programmes: cotton, easy care
- Special drying programs:
 - Cottons,
 - Shirts/Blouses: designed to allow immediate ironing or hanging up shirts/blouses after the program completes. Cotton Eco Down Wear: clothing, bedspreads or eiderdowns stuffed with down. Delicates: items made from satin, synthetic or blended fabrics Towels: hard wearing towels and dressing gowns made of cotton Mixed: items made from cotton or blended fabrics Super 40': short program for synthetic fabrics and light cottons Sportswear: sports and leisure items made from synthetic fibers, microfiber or fleece Quilts: clothing, pillows, quilts or bedspreads filled with synthetic fibres Easy Care: items made from synthetic or blended fabrics Wool: Machine washable items made of wool Timed Program Cold: manually set a custom time for loosening up or airing clothing that has hardly been worn Timed Program Warm: manually set a custom time for drying slightly damp or multi layered thick items
- Touch control option settings: Iron dry, Cupboard dry, Cupboard dry+, Finished in (delayed start): you can delay the start of the program by up to 24 hours, Half load option: optimises the drying settings (load and duration) for small loads., Easy Iron: the drum moves the laundry at regular intervals after drying to prevent creasing, Low Heat: reduce the drying temperature for delicate fabrics, End Signal: activate or deactivate the audible signal at the end of the program, Start/Pause the program, 24 h Finished in (delayed start): you can delay the start of the program by up to 24 hours

Performance

- Anti crease cycle 120 min at the end of the program
- Half Load option: optimizes drying for smaller loads
- Operating noise level: 64 dB(A)

Features

- ActiveAir heat pump technology, existing heat is reused efficiently during the entire drying process
- Sensitive drying system: textile friendly drum design and SoftFlow paddles ensure soft, fluffy laundry and helps to reduce creasing
- Easy Clean Filter
- Time delay to select end of time of your wash (1-24 hours) and time remaining indicator
- 2 time-based programs
- 7 Sensor-Care plus 2 time-based programs
- soft dial
- AntiVibration design: for greater stability and quietness

Design

- Large water condensation container: If there is no drain hose connected to the appliance the condensation water from the drying

- cycle will be stored in the condensation container
- Child safety control lock
- End of cycle indicator
- Glass door with 175 ° opening angle
- right-hinged

Technical Information

- Slide-under height of 85cm
- Dimensions (H x W x D): 84.2 cm x 59.8 cm x 61.3 cm (64.8 cm including door handle)

**Series 6, heat pump tumble dryer, 9
kg
WQG24200AU**

Measurements in mm

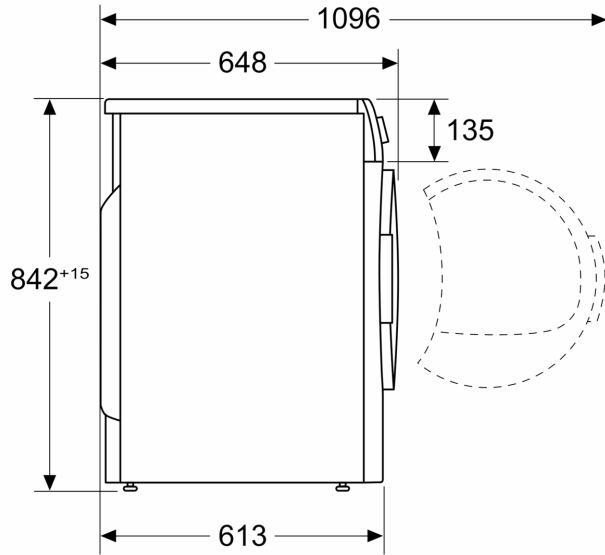

Measurements in mm

